

SAITO

**WITH STEAM ENGINE & BOILER
T-1 BOAT KIT**

T-1 スチームエンジン、B-1 ボイラー付

Assembling Instruction



Please carefully observe following cautions for the handling of

T-1 Steam Engine with B-1 boiler.

- Never use gasoline, thinner, etc. for the fuel.
Please do not place alcohol container near the burner but leave it at isolated location with cover once filled with alcohol.
- Do not look at the engine, boiler, burner or funnel from the top while the engine is in operation, as steam is discharged from the safety valve of boiler and exhaust system of engine and also, heat is generated from the funnel.
- Do not touch the boiler, burner or engine until it cools down as they are still very hot even after the operation is stopped.
- Never touch the screw propeller while it is turning.
- When the engine does not start, do not try to start the engine by turning screw propeller by hand as it is very dangerous.
- We are not liable for any damage or accident when the boiler or burner is used for other unintended purpose or incorrectly installed.
- Careful attention is also required during operation so as not to cause collision etc.

Careful attention is required in the handling of fire and never leave the engine unattended as long as the fire is used.

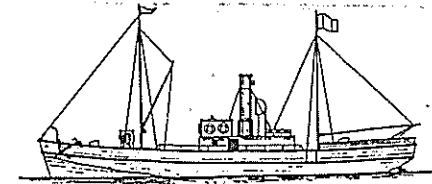
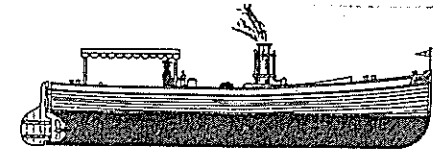
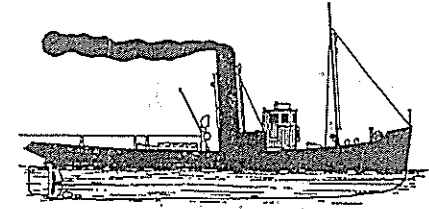

Cabin section can be built according to your taste.
Various types of ship can be built for your personal appealing.
(Photo shows one of such examples.)

Model T-1 Steam Engine with B-1 Boiler

Production of the ship and good operating method

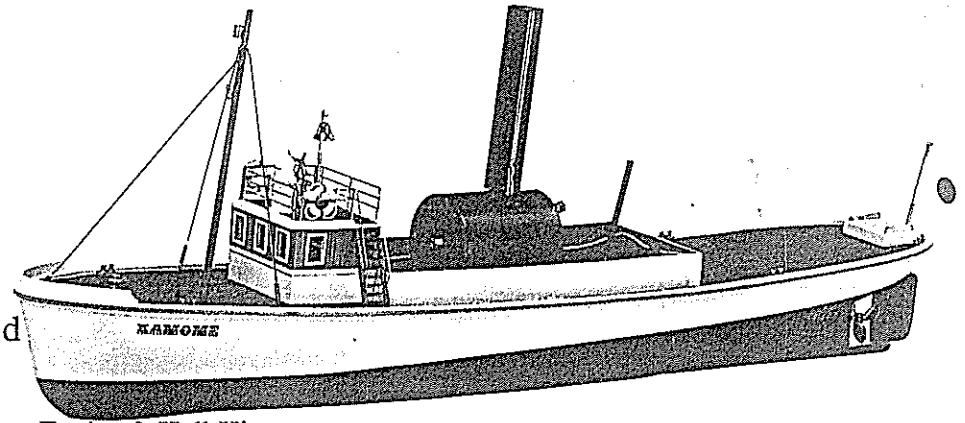

We thank you very much for your purchase of Model T-1 Steam Engine & Hull Kit.

For your better understanding of assembling sequences, we recommend you to go through this instruction booklet once before the start of your assembly work.

Before your assembly work:

T-1 steam engine is a single action type engine with piston valve system. It features: Bore: 8.8 mm, Stroke: 12 mm, Total length: 58 mm, Total width: 44.5 mm, Total height: 69.5 mm, Weight: 180 grms and Shaft diameter: 3 mm. B-1 boiler comes with a stoving type burner. Capacity of boiler is 90 cc. Use methanol (what is usually sold at the drugstore etc. are recommended as they offer good fire power) for burner as fuel. Burner contains 27 cc of fuel which burns for approximately 30 minutes (in winter). However, since it usually takes approximately 6 minutes for the steam to be saturated, net operating time would, therefore, be approximately 20 minutes.

- Contents of hull kit
- Glassfibre hull
- Screw propeller set
- Waterproof plywood
- Die-cut deck etc.

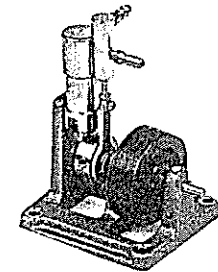

Data of white-gel-coated FRP hull are 740 mm (length) x 150 mm (beam) x 85 mm (height) and 360 grams in weight. To complete the ship, RC proportional servo control unit (just one channel is required for rudder control), drilling equipment, small saw, cutter, sand paper, file, silicon, caulking compound, 30 minutes curing type epoxy adhesive and paint (either lacquer or urethane paint is recommended) shall be prepared. For servo control unit, any unit can be used as no specific requirements are available in size or torque.

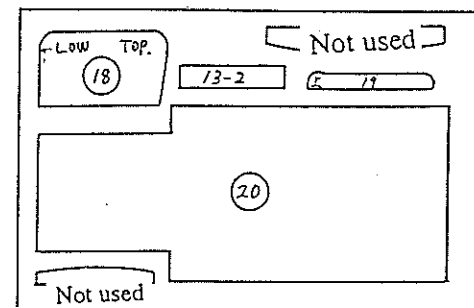
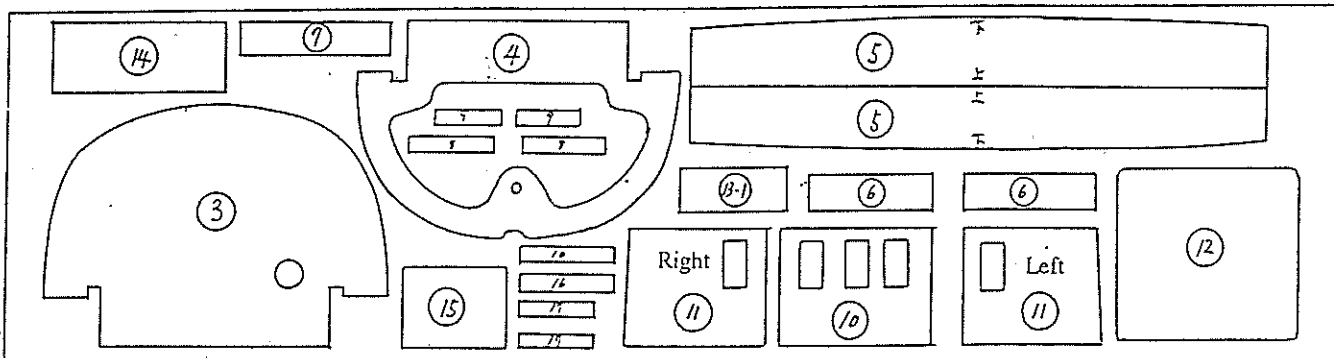
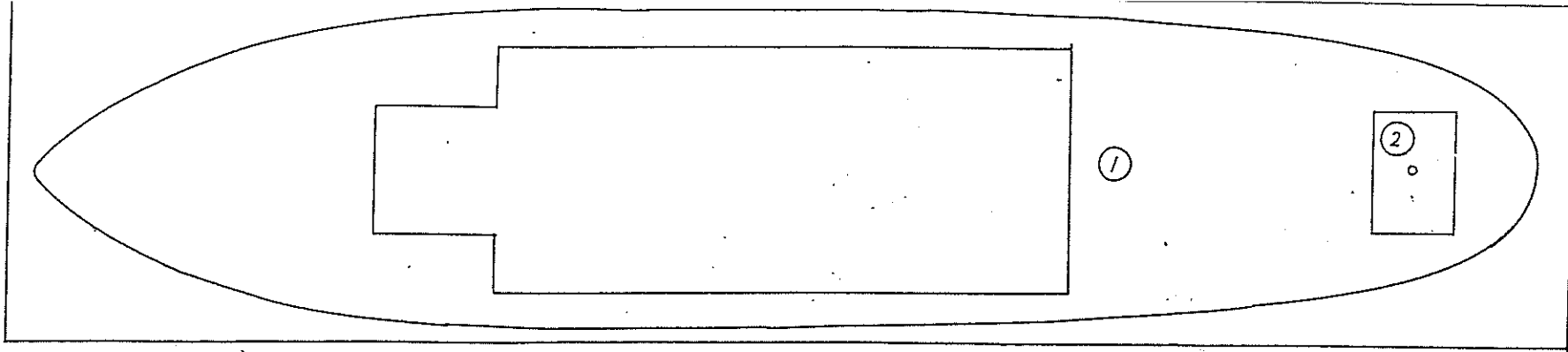

Wooden Parts No. List

Request to our customer: Prior to separate each piece part, please enter above numbers on each part. For assembly, place numbered face on the back so that each corner fits well when finished.

①

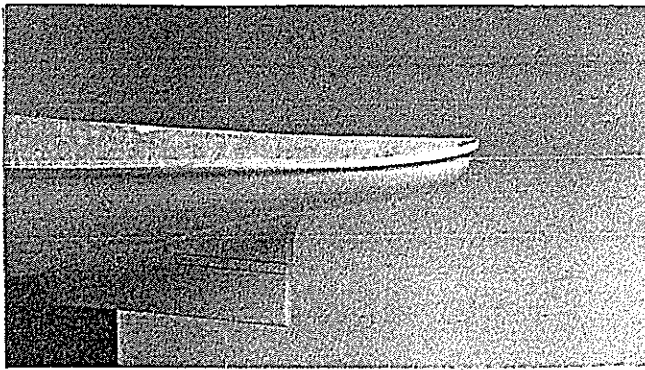

②

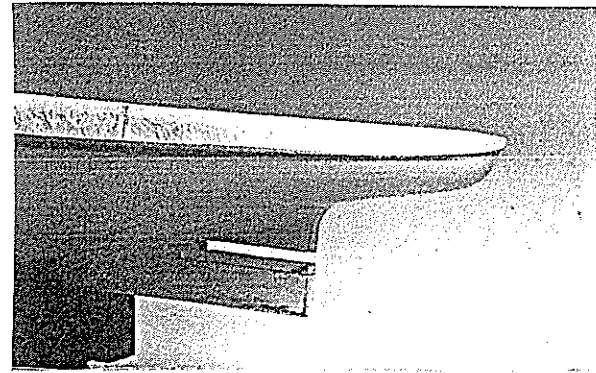

③

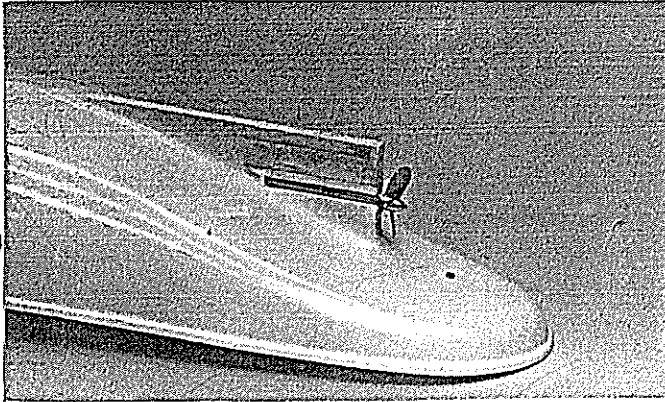

④

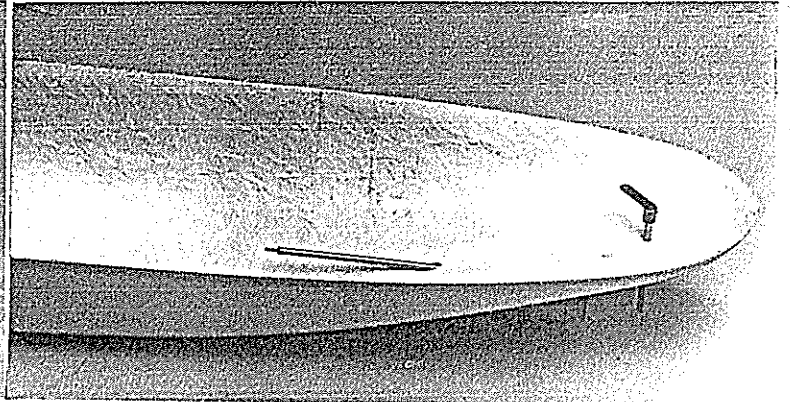

Hull work

First, saw off marked cut-out-section with hand saw and then, provide a hole for stern tube with a 5 mm Φ drill which is larger than stern tube by 1 mm.

Hull work at screw propeller section

- (1) Mark-off cut-out section for stern tube.
- (2) Sawing off.
- (3) Drill a hole and insert a stern tube.
- (4) Caulk space with epoxy adhesive from inside of hull.

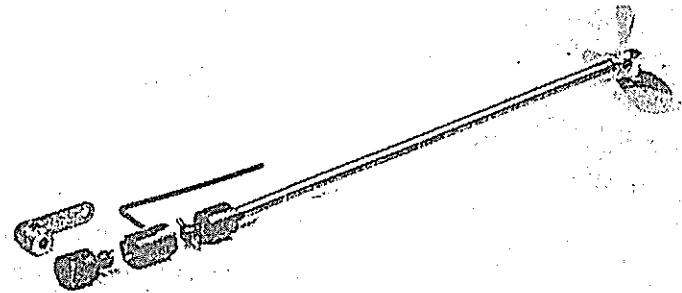

A: Hull production work

Put a deck plate (1) on the hull and mark the positions of (3) and (4). Cement parts (3) and (4) to the hull with epoxy adhesive.

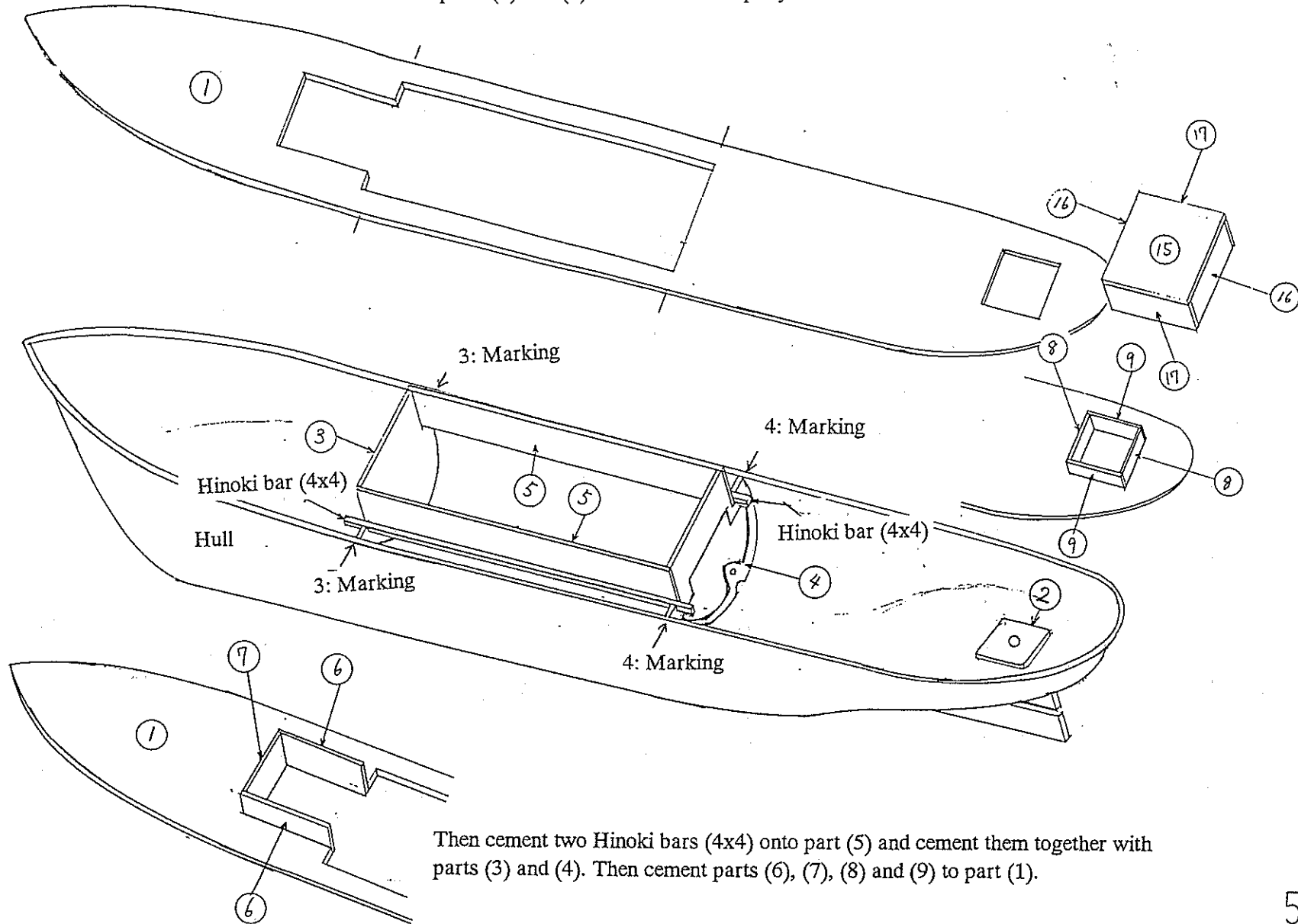

Then cement two Hinoki bars (4x4) onto part (5) and cement them together with parts (3) and (4). Then cement parts (6), (7), (8) and (9) to part (1).

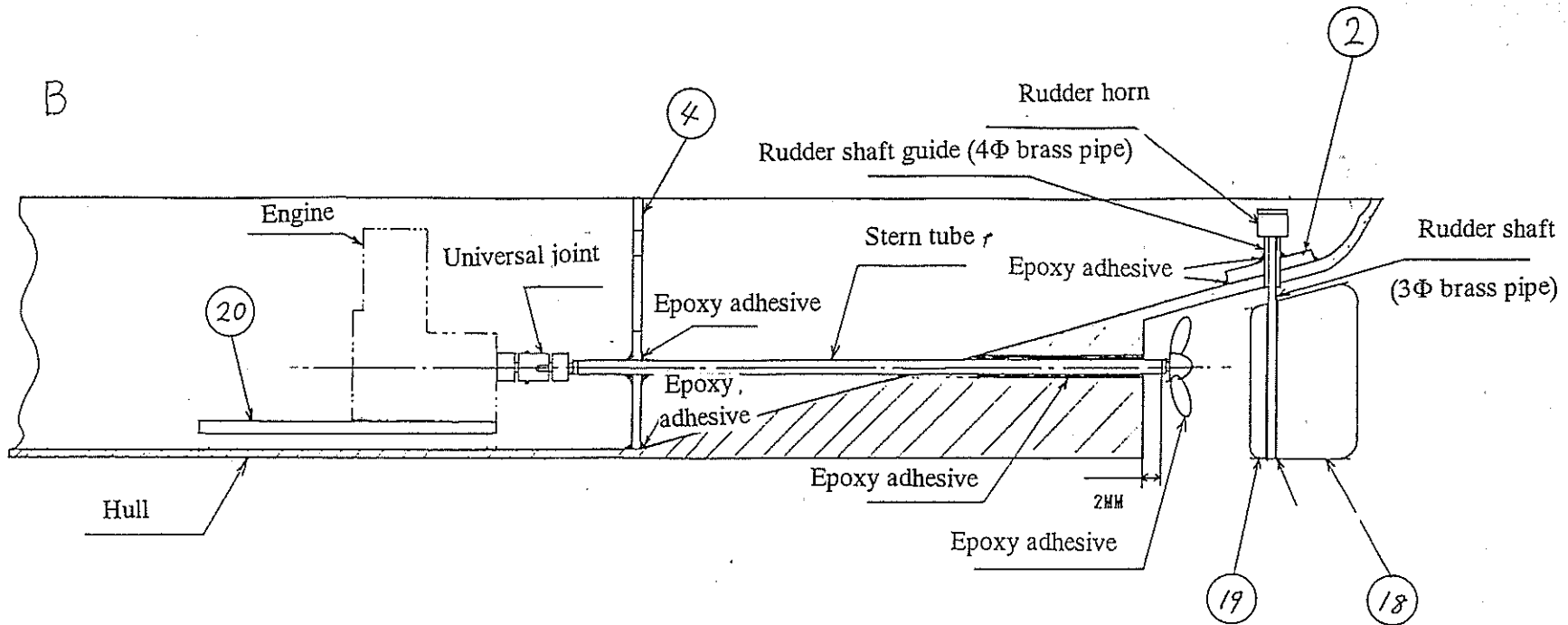

Let's install engine before deck plate (1) is cemented.

Prior to engine installation, insert propeller shaft into stern tube and attach screw propeller and universal joint to both ends of the shaft. Then, securely install engine bed (20) inside of the hull referring to Fig. B. Connect stern tube to the hull. Fill the space between the hull and stern tube with epoxy adhesive and form it with file or sand paper later.

Attach universal joint to the engine and provide gaps of about 1 mm at both left and right of intermediate joint and cement engine bed at the position where engine and propeller shaft turns smoothly by hand. Rudder shaft guide and part (2) shall also be cemented to the hull at this stage.

Provide boiler mounting knock pins (2 mm knock pins) by referring to P. 5.

After these internal work, finally cement deck plate (1) to the hull.

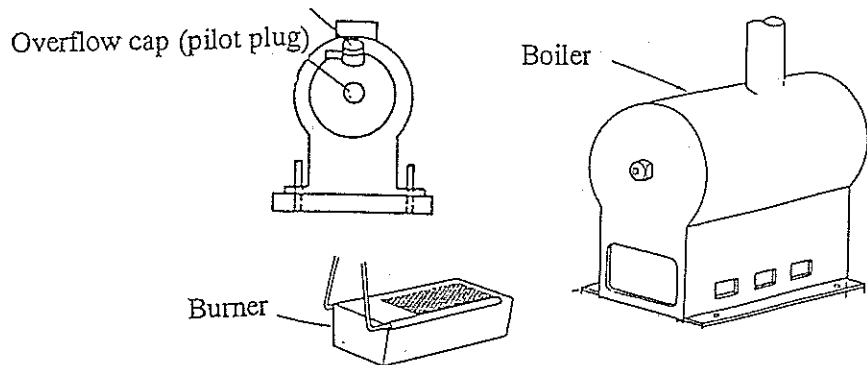

Operating procedure

- (1) First, horizontally place hull, remove pilot plug from boiler and feed water into boiler until water overflows from the plug. (Approx. 90 cc)
- (2) Feed alcohol into burner. (Approx. 25 cc)
- (3) Light burner.
- (4) Sufficiently lubricate engine, oiler, stern tube, universal joint, etc. with oil for automobile.

With the above, preparation for operation is completed.

Above sequence must be observed without fail.

If sequence of above (1) and (2) is changed, burning of boiler without water would be erroneously resulted.

Thus, careful attention shall be paid on this point.

To enable dismounting of the boiler from the hull, provide knock pins on the boiler base as illustrated (Sharpen tips) so that boiler can be installed from the top. (Prior to boiler installation, alcohol burner must be installed first.) Light the burner, thereafter.

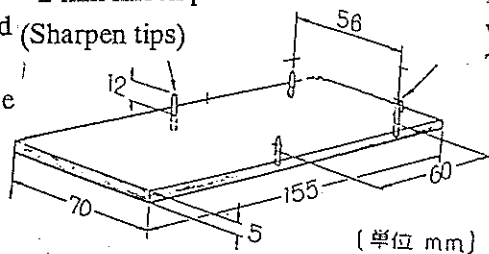

Boiler mounting base (20)

Warning!!

When excessive quantity of alcohol is filled into fuel tank, overflowed alcohol makes flame larger and the ship catches a fire. Therefore, make sure that the quantity of fuel is less than the specified quantity.

If operation is carried out in the room, make sure no material which easily catches fire is available in the room.

If worst comes to the worst, cover it with prepared wet towel and put water to extinguish. When water is put onto alcohol, alcohol is promptly neutralized by water and fire is extinguished.

Careful attention is required in the handling of fire and never leave the engine unattended as long as the fire is used.

T-1 steam engine is a single action type engine with piston valve system. It features: Bore: 8.8 mm, Stroke: 12 mm, Total length: 58 mm, Total width: 44.5 mm, Total height: 69.5 mm, Weight: 180 grms and Shaft diameter: 3 mm. B-1 boiler comes with a stoving type burner. Capacity of boiler is 90 cc. Use methanol (what is usually sold at the drugstore etc. are recommended as they offer good fire power) for burner as fuel. Burner contains 27 cc of fuel which burns for approximately 30 minutes (in winter). However, since it usually takes approximately 6 minutes for the steam to be saturated, net operating time would, therefore, be approximately 20 minutes.

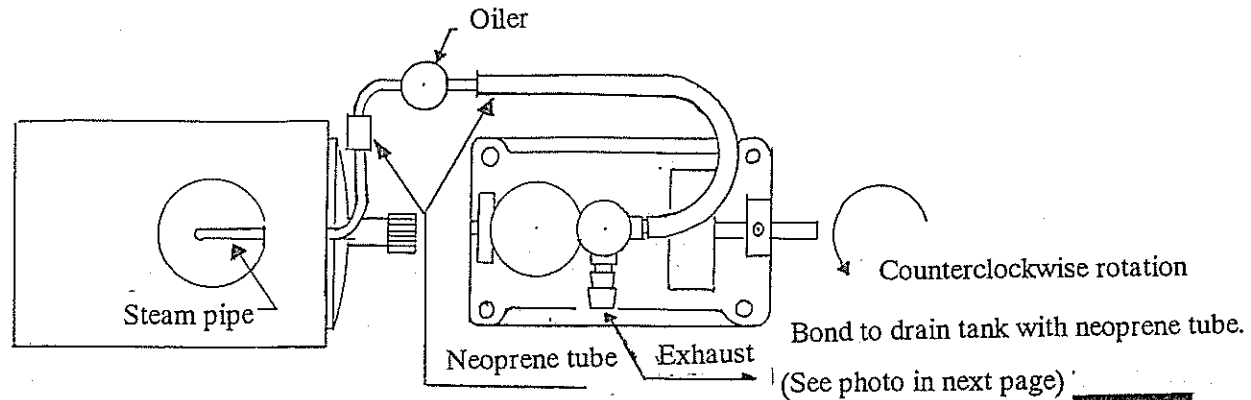

Fix rudder servo into front mechanism chamber with one-touch-tape etc.
 Angle of rudder must be set approximately 30 degrees maximum.
 Too large rudder angle would cause loss of power when the rudder is activated.

For the operation of transmitter/receiver, refer to the respective instruction manual.

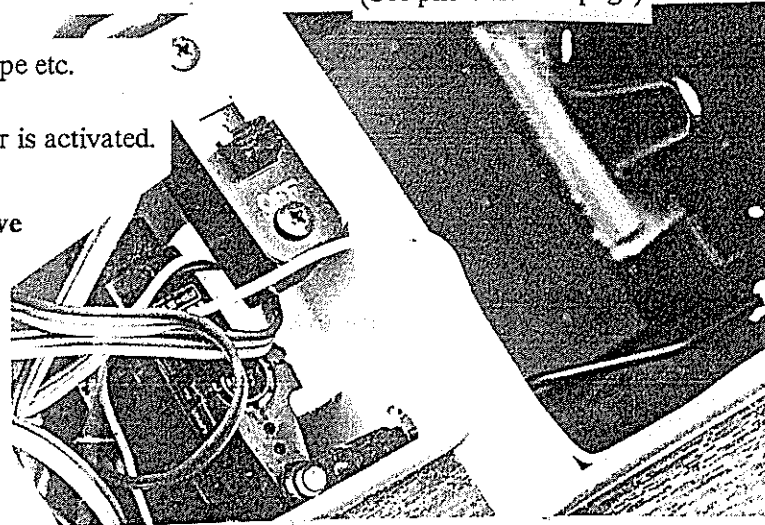

Cabin fittings

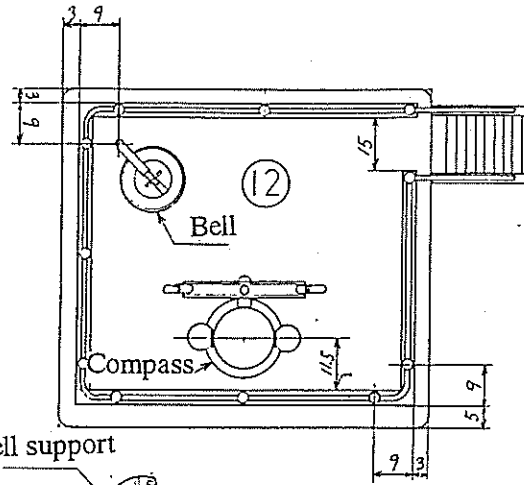
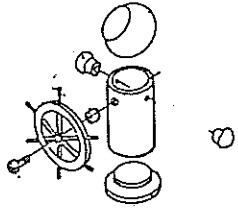

Bell support

Handrail, 1Φ brass wire
Handrail support Life saving float

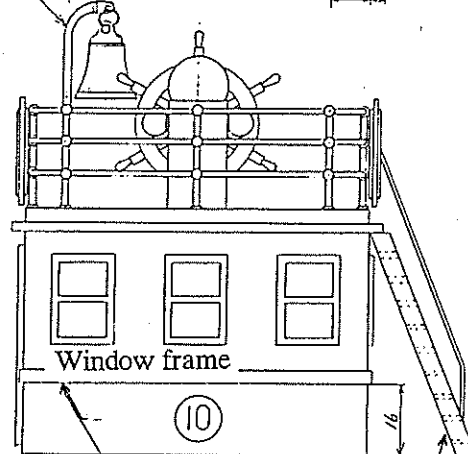
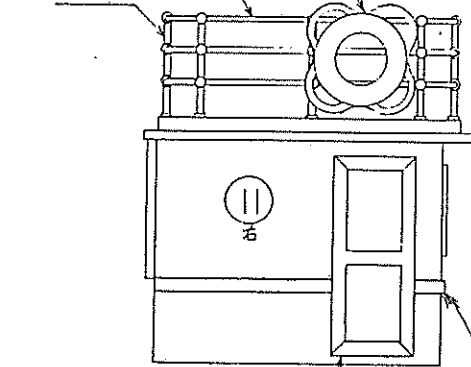

1x3 ABS material 3x3 ABS material

Make door frame with balsa material

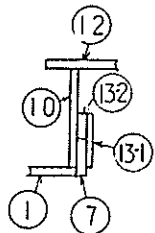

Cabin shift preventing assembly

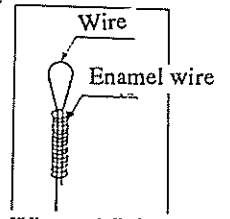
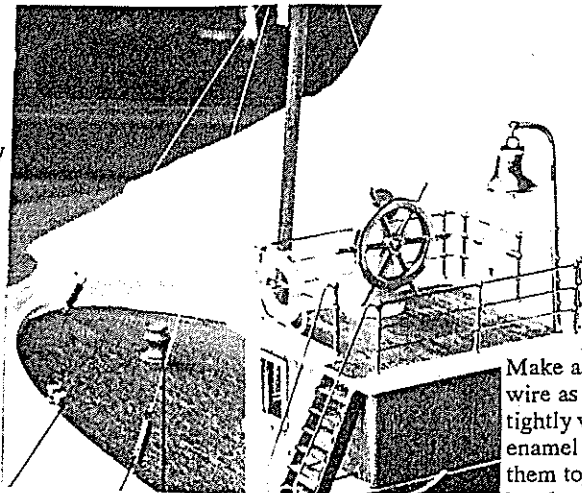
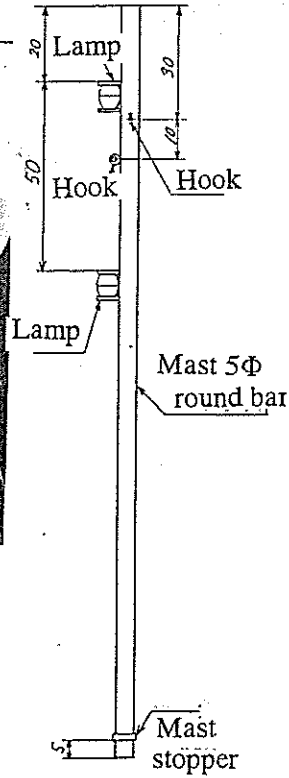
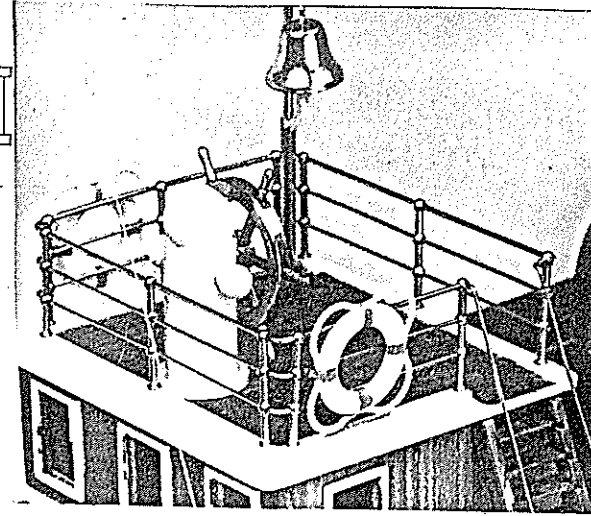
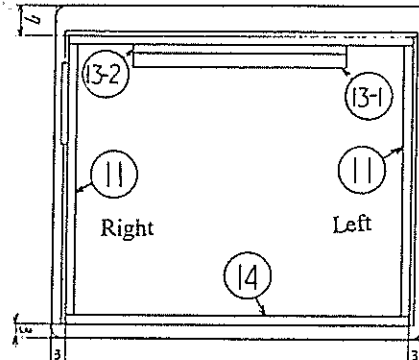

Wire end finish
Make a ring with double wire as illustrated, tightly wind wire with enamel wire and cement them together with instant bond and cut off extra wire.

Pollution preventing means?

As direct output of exhaust contaminates water, attach pollution preventing drain tank using an empty photo film case. Accumulated waste oil shall be recovered and processed after surface steaming run.

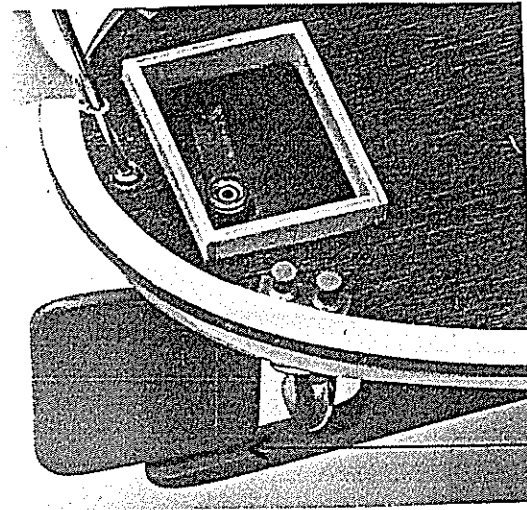
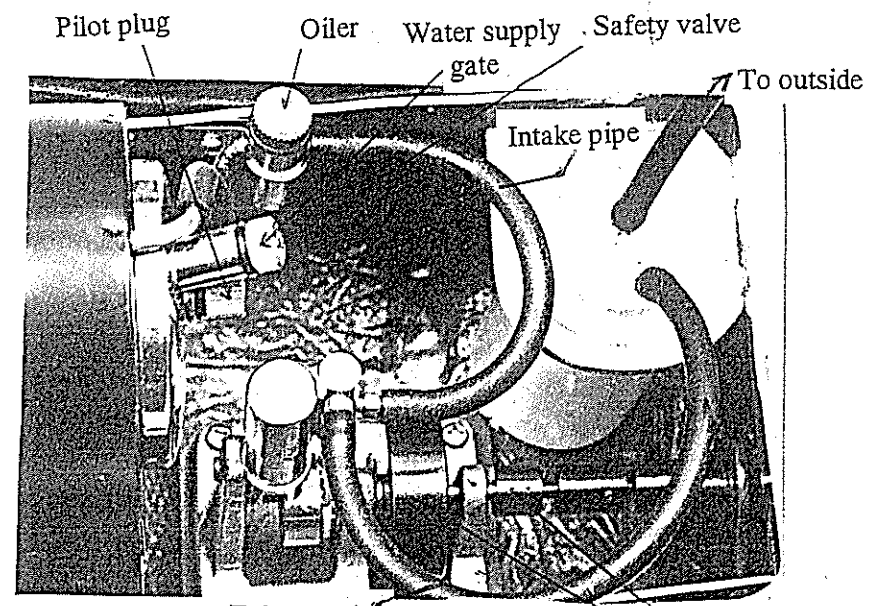
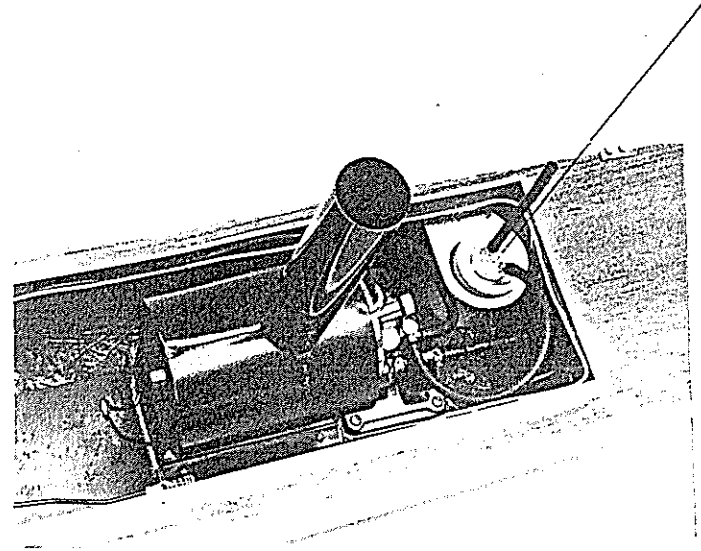

Bonding rudder to rudder shaft

Rudder shaft

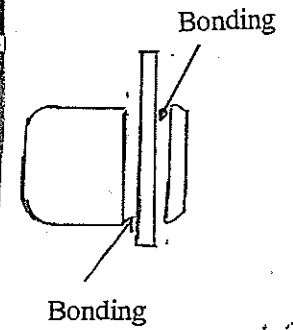
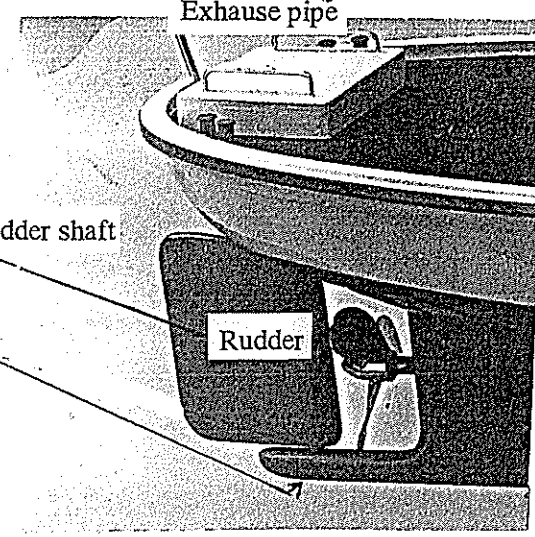

Warning!!

When excessive quantity of alcohol is filled into fuel tank, overflowed alcohol makes flame larger and the ship catches a fire. Therefore, make sure that the quantity of fuel is less than the specified quantity.

If operation is carried out in the room, make sure no material which easily catches fire is available in the room.

If worst comes to the worst, cover it with prepared wet towel and put water to extinguish.

When water is put onto alcohol, alcohol is promptly neutralized by water and fire is extinguished.

⊙ Careful attention is required in the handling of fire and never leave the engine unattended as long as the fire is used.

Use of gasoline or thinner is absolutely prohibited.

Specified alcohol quantity: 25 cc or less

Let's make first run!

For the first run, choose the day with less wind and start from leeward to windward without fail. Also, try to recover the ship about 3 minutes before net operating time expires. After fittings (extra parts) are attached, total weight of completed ship became about 1500 grams. As the center of gravity may shift upward depending upon the weight of fittings, careful adjustment of the ballast is required while looking

at the attitude of the ship on the water.

It is important to reduce the weight of erection such as fittings as light as possible. With heavy upper structure, much ballast is required which results in deep draft and slower speed.

Lastly, attention is required in the handling of alcohol. Since alcohol has hydrophilic property, its performance is deteriorated when it is left without a cap. Therefore, container cap must be securely tightened after use.

For the first run, hold the ship with a string etc. and observe operating time and running condition. Make sure that the propeller is kept in the water at all times during this test run. No load operation causes overspeed of engine and engine life is reduced. Also, as the engine has single cylinder with single action, restart can not be made.

When the pressure of boiler has increased as the steam is produced from the safety valve after about 4 to 6 minutes, start engine by turning flywheel by hand in counterclock direction viewed from joint side. When the engine does not start, do not try to start engine by hand by turning the propeller as it is very dangerous.

WITH STEAM ENGINE & BOILER T-1 BOAT KIT

T-1 スチームエンジン、B-1 ボイラー付 TECHNICAL DATA KIT

LENGHT	730%
BEAM	150%
HEIGHT	80%
ENGINE	T-1
BOILER	B-1
RADIO	1ch

仕 様

全 長	730%
全 幅	150%
全 高	80%
エンジン	T-1
ボイラー	B-1
RC装置	1ch



(有) 齊藤製作所

SAITO SEISAKUSHO, LTD.

T-1 STEAM ENGINE. B-1 BOILER. BURNER
F.R.P. HULL. DECK PLATE (ACCURATELY
CUT WATER PROOF PLYWOOD). UNIVER-
SAL JOINT, STERN TUBE, SHAFT, SCREW
PROPELLER, RUDDER SHAFT, FUNNEL

キット内容

T-1スチームエンジン、B-1ボイラー、バーナー、
グラスファイバー船体、甲板（耐水合板ダイカッ
ト済）、ユニバーサルジョイント、スタンチューブ、
シャフト、プロペラ、舵用シャフト、ラダーホー
ン、煙突。

22-7, TOKAGI 3-CHOME, ICHIKAWA-SHI
CHIBA-KEN, 272 JAPAN
PHONE: 0473-78-4156 FAX: 0473-78-4155

〒272 千葉県市川市稲荷木3丁目22-7
TEL: 0473-78-4156 FAX: 0473-78-4155